

FIBER OPTIC RECEIVING MODULE

TORX177(F,T)

FIBER OPTIC RECEIVING MODULE
FOR DIGITAL AUDIO INTERFACE

Unit: mm

- For JEITA Standard CP-1212
(Digital Audio Optical Interface
for Consumer Equipment).
- A self-tapping hole for easy attachment to
Audio Equipments panels.
- RoHS Compatible

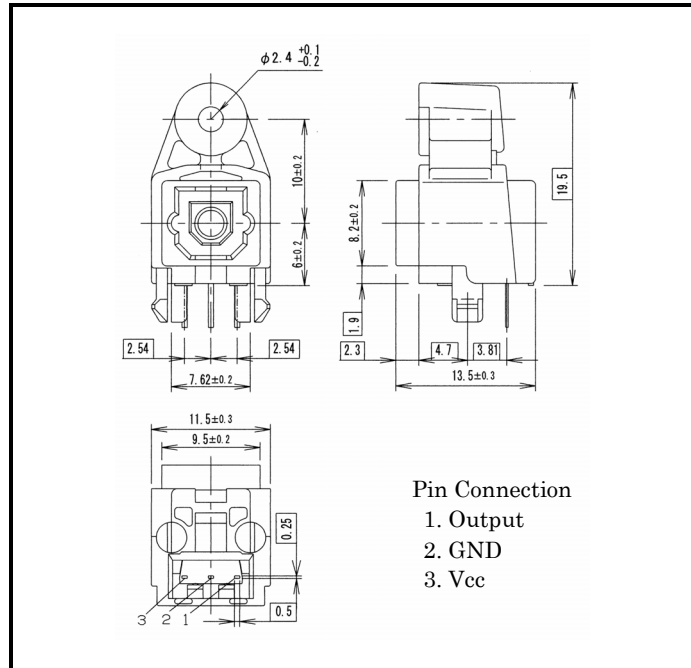

1. Absolute Maximum Ratings (Ta = 25°C)

Characteristics	Symbol	Rating	Unit
Storage Temperature	T _{stg}	-40 to 70	°C
Operating Temperature	T _{opr}	-20 to 70	°C
Supply Voltage	V _{CC}	-0.5 to 6	V
High Level Output Current	I _{OH}	-1	mA
Low Level Output Current	I _{OL}	5	mA
Soldering Temperature	T _{sol}	260 (Note 1)	°C

Note 1: Soldering time ≤ 10 seconds (At a distance of 1 mm from the package).

2. Operating Range

Characteristics	Symbol	Min	Typ.	Max	Unit
Supply Voltage	V _{CC}	4.75	5.0	5.25	V

3. Electrical and Optical Characteristics (Ta = 25°C, VCC = 5 V)

Characteristics	Symbol	Test Condition	Min	Typ.	Max	Unit
Data Rate		NRZ code (Note 2)	0.1	---	15	Mb / s
Transmission Distance		Using APF (Note 3), Using TOTX177(F,T)	0.2	---	5	m
Pulse Width Distortion (Note 4)	Δt_w	Pulse Width = 67 ns Pulse Cycle = 134 ns $C_L = 10$ pF Using TOTX177(F,T)	-15	---	15	ns
Maximum Receivable Power (Note 5)	P _{MAX}	15 Mb / s, Using APF	-14.5	---	---	dBm
Minimum Receivable Power (Note 5)	P _{MIN}	15 Mb / s, Using APF	---	---	-24	dBm
Current Consumption	I _{CC}		---	10	15	mA
High Level Output Voltage	V _{OH}		3.6	4.5	---	V
Low Level Output Voltage	V _{OL}		---	0.2	0.4	V

Note 2: 7.5Mb/s (max.) Biphase marked signal.

When modulated optical high level signal is received, output signal is high.

When modulated optical low level signal is received, output signal is low.

When non-modulated signal (optical all high or all low level signal) is inputted, output signal is not stable.

Note 3: All Plastic Fiber (980 / 1000 μm).

Note 4: Between input of TOTX177(F,T) and output of TORX177(F,T).

Note 5: BER ≤ 10⁻⁹, peak value.

4. Mechanical Characteristics (Ta = 25°C)

Characteristics	Symbol	Test Condition	Min	Typ.	Max	Unit
Insertion Force (Note 6)		Initial value	---	---	39.2	N
Withdrawal Force (Note 6)		Initial value	5.9	---	39.2	N
Torque for Self-Tap		Using self-tapping screw (M3 × 8)	58.8	---	98	N-cm

Note 6: Square type connector : EIAJ RC-5720B

5. Application Circuit

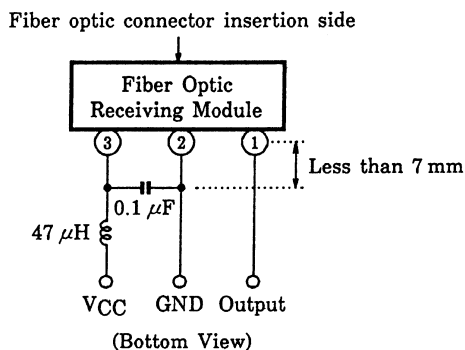

6. Required Optical Fiber with Fiber Optic Connectors

All Plastic Fiber with Square Type Connector (EIAJ RC-5720B)

7. Board layout hole pattern (Recommendation)

Unit: mm
 Tolerance: ± 0.05 mm
 Recommended PCB thickness: 1.6 mm

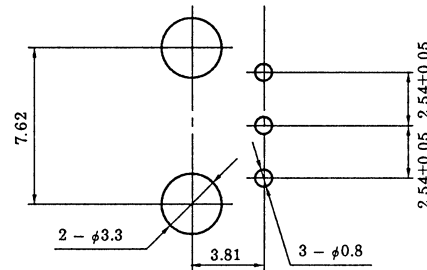

8. Precautions on Use

(1) Absolute maximum rating

The absolute maximum ratings are the limit values which must not be exceeded during operation of device. None of these rating value must not be exceeded. If the absolute maximum rating value is exceeded, the characteristics of devices may never be restored properly. In extreme cases, the device may be permanently damages.

(2) Soldering

Optical modules are comprised of internal semiconductor devices. However, in principle, optical modules are optical components. During soldering, ensure that flux does not contact with the emitting surface or the detecting surface. Also ensure that proper flux removal is conducted after soldering. Some optical modules come with a protective cap. The protective cap is used to avoid malfunction when the optical module is not in use. Note that it is not dust or waterproof.

As mentioned before, optical modules are optical components. Thus, in principle, soldering where there may be flux residue and flux removal after soldering is not recommended. Toshiba recommend that soldering be performed without the optical module mounted on the board. Then, after the board has been cleaned, the optical module should be soldered on to the board manually.

If the optical module cannot be soldered manually, use non-halogen (chlorine-free) flux and make sure, without cleaning, there is no residue such as chlorine. This is one of the ways to eliminate the effects of flux. In such a cases, be sure to check the devices' reliability.

(3) Noise resistance

It is believed that the use of optical transfer devices improve noise resistance. In theory, optical fiber is not affected by noise at all. However, receiving modules which handle signals whose level is extremely small, are susceptible to noise.

TOSLINK improve noise resistance to use a conductive case. However, the current signal output by the optical receiving modules' photodiode is extremely small. Thus, in some environments, shielding the case may not achieve sufficient noise resistance.

For systems which incorporate TOSLINK, Toshiba recommend testing using the actual device to check its noise resistance.

Use a simple noise filter on TOSLINK fiber optic transceiving module's power line. If the ripple in the power supply used is significant, reinforce the filter.

The optical module is to be used in an area which is susceptible to radiated noise, increase the shielding by covering the optical module and the power line filter with a metallic cover.

(4) Vibration and shock

This module is plastic sealed and has its wire fixed by resin. This structure is relatively resistant to vibration and shock. In actual equipment, there are sometime cases in which vibration, shock, or stress is applied to soldered parts or connected parts, resulting in lines cut. A care must be taken in the design of equipment which will be subject to high levels of vibration.

(5) Support pins

The TORX177(F,T) has support pins in order to fix itself to the PCB temporary. Please make the hole for these pins in the PCB under the condition described in board layout hole pattern.

- (6) Panel attachment
TORX177(F,T) has hole for panel attachment. Please be sure to attach it to panel with self-tapping screw.
- (7) Solvent
When using solvent for flux removal, do not use a high acid or high alkali solvent. Be careful not to pour solvent in to the optical connector ports. If solvent is inadvertently poured in to them, clean it off using cotton tips.
- (8) Protective cap
When the TORX177(F,T) is not in use, attach the protective cap.
- (9) Supply voltage
Use the supply voltage within the recommended operating condition ($V_{CC} = 5 \pm 0.25 \text{ V}$). Make sure that supply voltage does not exceed the maximum rating value of 6 V, even for an instant.
- (10) Interface
The TORX177(F,T) has a TTL interface. It can be interfaced with any TTL-compatible C-MOS IC.
- (11) Output
If the receiver output is at low and is connected to the power supply, or if the output is high and is connected to GND, the internal IC may be destroyed.
- (12) Soldering condition
Solder at 260°C or less for no more than ten seconds.
- (13) Precautions when disposing of devices and packing materials.
When disposing devices and packing materials, follow the procedures stipulated by local regulations in order to protect the environment against contamination.
- (14) Precautions during use
Toshiba is continually working to improve the quality and the reliability of their products. Nevertheless, semiconductor devices in general can malfunction or fail due to their inherent electrical sensitivity and their vulnerability to physical stress. It is the responsibility of the buyer, when utilizing Toshiba products, to observe standards of safety, and to avoid situations in which the malfunction or failure of a Toshiba product could cause loss of human life, bodily injury or damage to property.
When developing equipment, please ensure that Toshiba products are used within the specified operating ranges set forth in the most recent product specifications. Also, please keep in mind the precautions and conditions set forth in the Toshiba Semiconductor Reliability Handbook.

RESTRICTIONS ON PRODUCT USE

- The information contained herein is subject to change without notice.
- TOSHIBA is continually working to improve the quality and reliability of its products. Nevertheless, semiconductor devices in general can malfunction or fail due to their inherent electrical sensitivity and vulnerability to physical stress. It is the responsibility of the buyer, when utilizing TOSHIBA products, to comply with the standards of safety in making a safe design for the entire system, and to avoid situations in which a malfunction or failure of such TOSHIBA products could cause loss of human life, bodily injury or damage to property.
In developing your designs, please ensure that TOSHIBA products are used within specified operating ranges as set forth in the most recent TOSHIBA products specifications. Also, please keep in mind the precautions and conditions set forth in the "Handling Guide for Semiconductor Devices," or "TOSHIBA Semiconductor Reliability Handbook" etc..
- The TOSHIBA products listed in this document are intended for usage in general electronics applications (computer, personal equipment, office equipment, measuring equipment, industrial robotics, domestic appliances, etc.). These TOSHIBA products are neither intended nor warranted for usage in equipment that requires extraordinarily high quality and/or reliability or a malfunction or failure of which may cause loss of human life or bodily injury ("Unintended Usage"). Unintended Usage include atomic energy control instruments, airplane or spaceship instruments, transportation instruments, traffic signal instruments, combustion control instruments, medical instruments, all types of safety devices, etc.. Unintended Usage of TOSHIBA products listed in this document shall be made at the customer's own risk.
- The information contained herein is presented only as a guide for the applications of our products. No responsibility is assumed by TOSHIBA for any infringements of patents or other rights of the third parties which may result from its use. No license is granted by implication or otherwise under any patent or patent rights of TOSHIBA or others.
- Please use this product in compliance with all applicable laws and regulations that regulate the inclusion or use of controlled substance. TOSHIBA assumes no liability for damage or losses occurring as a result of noncompliance with applicable laws and regulations.
- TOSHIBA products listed in this document are designed and manufactured for usage in home audio equipment .TOSHIBA products are neither intend nor warranted for uasge in equipment other than home audio equipment. TOSHIBA products listed in this document shall not be used for usage other than home audio equipment.